



GNSS Interference Suppression Techniques: A Survey

Moustafa Abd El-Rahman¹, Mohamed A. Elharmil², Roshdy A. Abdelrassoul^{3,*}, Mohamed S. Zaghoul⁴ and Mohamed El Ghamry⁵

Citation: Abd El-Rahman, M.; Elharmil, M. A.; Abdelrassoul, R. A.; Zaghoul, M. S.; El Ghamry, M. *International Journal of Telecommunications, IJT* 2021, Vol. 01, Issue 01, pp. 1-10, December 2021. <https://ijt-adc.org/articles/2805-3044/810747>

Editor-in-Chief: Yasser M. Madany

Received: 25-11-2021

Accepted: 15-12-2021

Published: 18-12-2021

Publisher's Note: The International Journal of Telecommunications, IJT, stays neutral regarding jurisdictional claims in published maps and institutional affiliations.



Copyright: © 2021 by the authors. Submitted for possible open access publication under the terms and conditions of the International Journal of Telecommunications, IJT, Air Defense College, ADC, (<https://ijt-adc.org>) and conditions of the Creative Commons Attribution (CC BY) license (<http://creativecommons.org/licenses/by/4.0/>).

¹ AASTMT; sufwahab@gmail.com

² AASTMT; mohamed_elharmel@yahoo.com

³ AASTMT; Life SM IEEE, roshdy@ieee.org

⁴ AASTMT; Dr_mszaghloul@yahoo.com

⁵ AASTMT; Mohamed@elghamry.net

* Correspondence: roshdy@ieee.org; Tel.: +02 100 3550 8825

Abstract: Positioning is very important worldwide in several fields, and it can be determined by several ways. The most popular ways are Global Navigation Satellite System (GNSS) and Inertial Navigation Systems (INS). Both techniques have advantages and disadvantages. Accurate positioning is one of the privileges of GNSS, while INS overtops in indoor places, despite low accuracy after long duration. Sensibility to interference and multipath are the principal downsides of GNSS structure, which might be the two primary assets of mistakes in position estimations. The main impact of interference at (GNSS) receiver, consequently dropping its cap potential to navigate, is that it lessens the signal to noise ratio (SNR) of navigational signal such that the receiver is not able to reap measurements from the satellite. A comprehensive survey of interference suppression methods is presented in this paper and the interference suppression techniques are compared. Two new recommended filter designs to detect spoofing and optimize acquisition in the presence of interference are proposed.

Keywords: Global navigation satellite system (GNSS); inertial navigation systems (INS); cross ambiguity function (CAF); signal to noise ratio (SNR); interference suppression.

1. Introduction

Interference counter can be in space, frequency, time or space-time, space-frequency. Spatial algorithms to counter interferences are divided into classes consistent with their goals. Digital Beam Forming (DBF) is one of them [1], which aims the principal lobe spontaneous to the favored alerts. The second method is Adaptive Nulling approach [2], which factors nulls to interference. The DBF calls for the path facts of GNSS alerts and its computation is pretty complicated. Thus, increasing mistakes of the estimation on GNSS alerts path degrade overall interference mitigation performance seriously. On the contrary, the Adaptive Nulling approach, which is known as a blind suppression method, does now no longer needs any previous information the interferences. One of the benefits of Adaptive Nulling approach is that it no longer uses any transcendental facts, but nulls can be too huge with inside interference paths and many 'incorrect' nulls with inside noninterfering paths. In order to overcome the above-mentioned troubles, based on GNSS signals' property of periodic repetition, a Self-Coherence Recovery (SCORE) technique is proposed by Agee [3]. Without understanding the path of GNSS alerts, an auxiliary channel is provided precisely after the prime channel. Most excellent weights are calculated thru maximizing the cross-correlation of alerts among principal and auxiliary channels below the Least Square principle. This approach, now no longer simplest, could make the profits in a few GNSS alerts path as excessive as possible, however can also shape deep nulls within inside the path of jammers spontaneously. However, this approach is not able to assure that the principal beam to align at each GNSS signal. If the profits of the non-jamming path

stay unchanged, the above troubles of Adaptive Nulling could be averted with the aid of using a new interference mitigation approach proposed to resolve the above-noted troubles [4]. Using adaptive array in GPS receivers is the most popular solution to counter interference spatially. Advantages are tuning gain and phase adaptively according to interference environment, thus directing pattern nulls towards the interference path to fade interference. On the other hand, spatial filter additionally has shortcomings. The limitation of countering interference is that the maximum number interferences that can be removed is $M-1$ nullings for M antenna elements; and as the direction of arrival (DOA) of GPS satellite alerts is aligned with interference supply or near to it, nulling will harm the GPS signal till it is unavailable [5]. To overcome the shortage of range of countering interference and increase elements degrees of freedom (DOF) without including elements is treated by Space-time Adaptive Processing (STAP) [6]. STAP is considered as the upgrade of interference mitigation methods for GPS receiver. In this paper, Section 2 discusses interference suppression methods. Section 2.1 discusses the Self-Coherence Recovery (SCORE) set of rules, whilst Section 2.2 critiques the multi-goal optimization jamming mitigation set of rules, and Section 2.3 affords the space-time adaptive processing (STAP) era. Section 2.4 presents Fast Orthogonal Search (FOS) technique, Section 2.5 demonstrates dual polarized antenna technique, and Section 2.5 demonstrates pulse on pulse deinterleaving method. Section 3 presents a comparison of the above-mentioned suppression methods, and Section 4 presents two proposed design filters to improve interference suppression. Section 5 is a conclusion.

2. Interference Suppression Methods

2.1. Score Algorithm Overview

This interference suppression method builds on the primary idea of the self-coherence restoral method proposed in [1]. At frequency separation β , if the correlation of the signal and its frequency shifted model is nonzero for some lag τ , it is known as spectrally self-coherent:

$$\rho_{ss}^{(\beta)}(\tau) = \frac{\langle s(t)s^*(t-\tau)e^{-j2\pi\beta t} \rangle_{\infty}}{\sqrt{\langle |s(t)|^2 \rangle_{\infty} \langle |s^*(t-\tau)e^{-j2\pi\beta t}|^2 \rangle_{\infty}}} = \frac{R_{ss}^{(\beta)}(\tau)}{R_{ss}(\tau)} \neq 0 \quad (1)$$

Where $(\)^*$ is the complex conjugate and $\langle \ \rangle_{\infty}$ is the infinite time averaging process, $\rho_{ss}^{(\beta)}(\tau)$ represents the self-coherence function, $R_{ss}^{(\beta)}(\tau)$ and $R_{ss}(0)$ are the cyclic autocorrelation function and the average power of $s(t)$, respectively. With the presence of inside enigmatic noise and interference Spectral Self-COherence REstoral (SCORE) beamforming methods were proven to blindly extract GPS signal [3]. Maximizing a degree of the cyclic characteristic of the beamformer output by seeking the beamformer weight vector is the main core of SCORE methods. If $s(t)$ is spectrally self-coherent at a frequency shift β , then the cyclic autocorrelation of the obtained signal may be expressed as [1]

$$R_{xx}^{(\beta)}(\tau) = |a|^2 R_{ss}^{(\beta)}(\tau) + R_{vv}^{(\beta)}(\tau) = |a|^2 R_{ss}^{(\beta)}(\tau) \quad (2)$$

Least-Squares (LS) SCORE, cross-SCORE and auto-SCORE are among several types of SCORE methods. The least squares (LS) SCORE is the simplest. Minimizing the difference between the reference signal and array output to determine weight vector of the array is its concept. This is achieved with the aid of using processing the lagged and frequency-shifted model of the obtained signal. Reinforcement cross-correlation of the output of the array and a reference signal to determine the beamformer is the concept of the cross-SCORE, and maximizing spectral self-coherence on the output of a linear combiner is the concept of the auto-SCORE technique [1].

2.2. A Multi-Objective Optimization Interference Mitigation Technique

An interference mitigation method is proposed in [4] to counter the issue that nulls toward to jammers are too vast and incorrect nulls troubles within inside the spatial adaptive jamming suppression algorithms. A brand-new method with 2-norm constraints is proposed in [4]. For conception realization, the Power Inversion (PI) [7] and Multiple Signal Classification (MUSIC) [8], to overcome deep and wrong nulls [4].

Calculating the most excellent weight vector is the basis of the maximum decisive part of the spatial adaptive nulling processing methods. Linearly Constrained Minimum Variance (LCMV) and subspace decomposition are used as models in [4]. For keeping all bearings unchanged, adding a constraint in the thematic Power Inversion (PI) [7] and Multiple Signal Classification (MUSIC) function [8] is required. Let

$$W^H \alpha = 1 \quad (3)$$

where α is a path vector of a particular path. Eq 3 aims to make the benefit of the path similar or identical to 1; specifically zero dB. Under 2-norm, for all bearings, Eq 3 may be presented as

$$\|W^H A - 1\|_2^2 = 0 \quad (4)$$

The term A represents bearing's vectors matrix. By including the (constraint (4)) to the original Power Inversion (PI) [7] and Multiple Signal Classification (MUSIC) [8], a brand-new criterion, primarily based totally on multi goal optimization can be achieved.

Obviously, from the experiments offered in [4], the proposed method in [4] has higher interference suppression cap potential and may enhance the location functionality of the receivers.

2.3. Space-Time Adaptive Processing (STAP)

STAP is proposed in [5], [6], [9] and is primarily based totally on the subspace orthogonal set of rules. Fig.1 shows STAP shape. It is considered as a powerful space-time signal processing method to suppress interference; spatial clear out and a temporal equalizer can be achieved simultaneously in STAP [9]. The STAP Model proposed in [9] is shown in Figure 1.

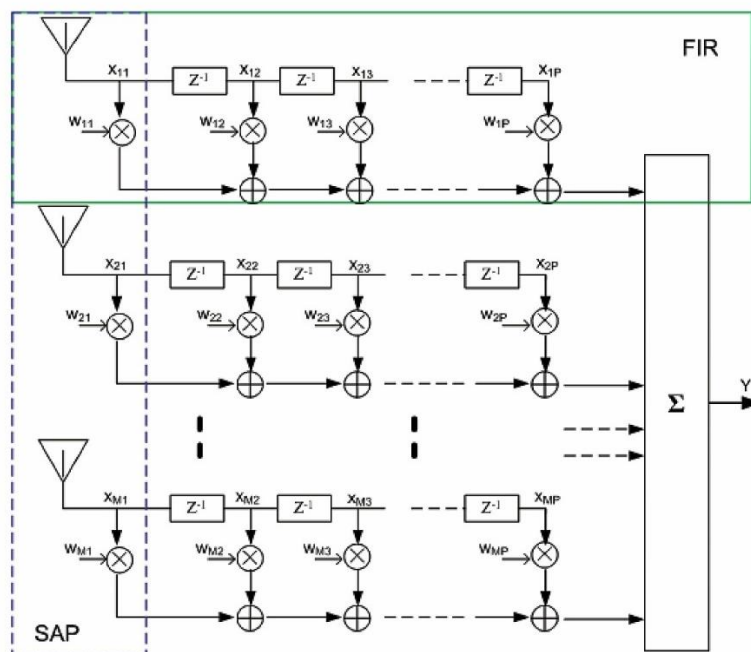

Figure 1. STAP Model proposed in [9].

A subspace method is used to dispose of robust interference with the aid of using projecting the incoming signal onto a subspace orthogonal to the interference subspace.

$$x(n) = \sum_{k=1}^K S_k(n) a_k(n) + \sum_{l=1}^L J_l(n) d_l(n) + N(n) \quad (5)$$

$x(n) = [x_1(n), x_2(n), \dots \dots x_M(n)]^T$ represents the received data by M array elements. Amplitude and direction vector are represented by $S_k(n)$, $a_k(n)$ of the k^{th} desired signal, respectively. Amplitude and direction vector of l^{th} interfering signal are represented by $J_l(n)$, $d_l(n)$, respectively. Overall number of received desired sign is denoted by K . Overall number of spurious signals is represented by L , and white noise with 0 mean and $\delta^2 I_M$ variance is represented by $N(n)$.

Using orthogonality, to reap array output can suppress unwanted alerts, and we will use the merits of vulnerable GPS alerts and robust unwanted alerts.

$$Y(n) = [\sum_{k=1}^K S_k(n)a_k(n) + \sum_{l=1}^L J_l(n)d_l(n) + N(n)]^H w = [\sum_{k=1}^K S_k(n)a_k(n) + N(n)]^H w \quad (6)$$

Simulation done in [9] displays that among spatial filtering methods STAP can correctly suppress unwanted signals in both spatial and temporal domain simultaneously. And we can get weight coefficients in a quick and adaptive manner with no requirement for previous information of desired signals by using of the subspace orthogonal set of rules.

2.4. Fast Orthogonal Search (FOS)

Using fast orthogonal search, and based on high-resolution spectral analysis, a novel interference mitigation method is proposed in [10]. The introduction of FOS was used by Kornberg in 1989 as a non-linear modeling technique [11-13]. Then for spectral model estimation, FOS was used successfully [14–15]. High resistance capabilities to white and colored noise [16-18], and better resolution in frequency compared to FFT which could be as low as one tenth of FFT resolution, subject to the signal-to-noise ratio (SNR), are the two remarkable features characterizing FOS and make it suitable for interference suppression [19].

Elghamrawy, et. al. [10] start by performing FFT to the incoming signal to get a coarse prediction of the interference frequency. Primarily, pairs of cosines and sines functions are generated, that are sinusoidal functions centered at the predicted frequency with a resolution in frequency that is one-tenth the FFT resolution. Then, the FOS interference suppression module constructs the interference signal as a functional expansion of these sinusoidal functions until one of the stop criteria is met by reaching pre-defined maximum number of model terms. Lastly, the estimated interference signal is subtracted from the receiving signal, leaving only the supposed to be GPS signal. Figure 2 presents the technique.

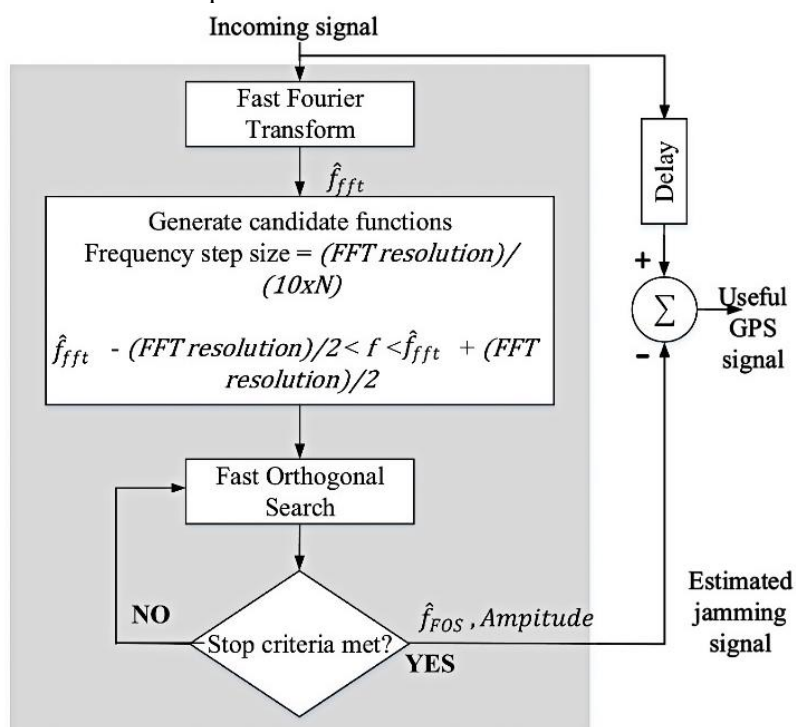

Figure 2. Flowchart of the anti-jamming technique proposed in [10].

2.5. Dual Polarized GPS Antenna Technique

Another approach to mitigate interference is proposed in [20]. The proposed Minimum-Variance-Distortionless-Response (MVDR)-based space-time adaptive processing (STAP) method is used to increase the Signal to Interference and Noise Ratio (SINR) and increase array freedom by using dual polarized co-located polarized dipole per element. Previous approaches using dual polarized antenna were demonstrated [21-24]. Table 1 shows a thorough comparison of different interference mitigation methods using dual polarized antenna [20], indicating the high SINR efficiency of the MVDR-based STAP approach.

Table 1. Comparison of interference suppression methods using dual polarized antenna arrays [20]

Approach	Technique	Interference polarizations tested	SINR Efficiency
[21]	PM-based STAP	linear and circular	moderate
[22 - 23]	MVDR-based SAP	RHCP , linear and circular	low
[24]	LMS-based SAP	arbitrary	low
[20]	MVDR-based STAP	arbitrary	high

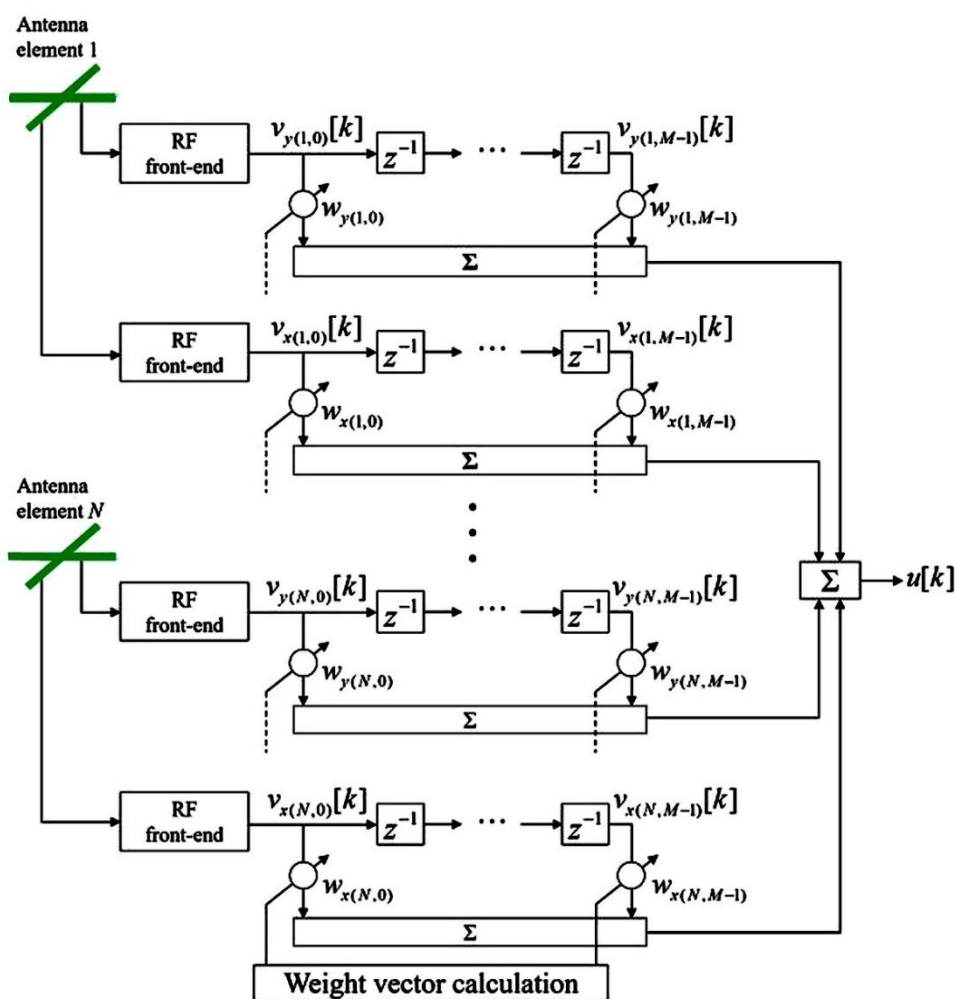

Figure 3. Block diagram of dual-polarized antenna array processing method proposed in [20].

For M elements, conventional arrays can counter $M-1$ interferences signals, after utilizing proposed technique in [20], $2M-1$ DOF can be achieved exploiting polarization characteristics of signal which depends on effective length of the antenna h . h is equal to one half of the physical length for short dipole and is same as the physical length of ideal dipole. As the GPS signal is a clockwise or right-handed circular polarization (RHCP), and by adding h as constraint in the calculations, the algorithm demonstrates high capability to mitigate interference, high SINR comparing to other methods, as in [21-24]. Increasing number of interference signals are countered and even if the interference signal was at the same direction of GPS signal, the technique is able to suppress the interference. The block diagram of proposed method in [20] is presented in Figure 3.

Another approach to mitigate interference for GPS [25] is called Space -Time – Polarization Adaptive Processing for a Single-element dual-polarized antenna (STPAPS). As antenna arrays are limited to be applicable by their size, cost and computational complexity, a single element polarized antenna is utilized, and performs MVDR – based STAP method, extending it to contain polarization domain to overcome size. To reduce computational complexity, an eigenvector constraint is added as a constraint to STPAPS. The approach in [25] demonstrates higher C/N_0 than minimum mean square error (MMSE) estimator methods. On the other hand, multiple spread spectrum interferences can't be mitigated.

2.6. Rearrangement Wavelet-Hough Transform method (RWHT)

Reference [26] introduces a new method to detect swept-spot interference, by combining a Rearranged Wavelet transform and Hough Transform (RWHT). It demonstrated time – frequency (TF) existing transforms used in GNSS receivers as Winger -Ville Distribution (WVD) and spectrogram and clarified the limitation in (TF) localization. They focus on combining wavelet transform with rearrangement operation and Hough transform to overcome existing limitation. Experimental results in [26] demonstrated a mitigation to cross terms problems and improve localization in TF -domain. RWHT is alliable to detect both CW and swept – spot jamming.

2.7. Pulse on Pulse Deinterleaving Method

Obtaining a clear signal without in-spurious noise can be achieved using Pulse on Pulse (POP) Deinterleaving Method demonstrated in [27]. A finite state machine (FSM) is used, and dynamic threshold based on Time of arrival (TOA), pulse width (PW) and the pulse repetition interval (PRI) of pulse train signals, generating five different pulses of amplitude 1 and 1 ms long with different PW and PRI. The obtained stacked signal is by combining the five pulses. The method can detect each single pulse depending on TOA, PW and PRI. Two thresholds are defined to help FSM keep tracking the position of the pulse [28].

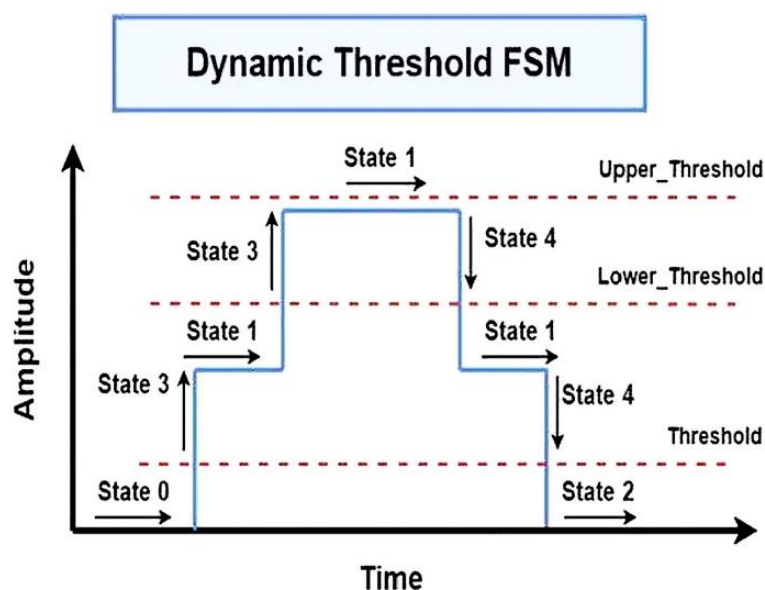

Figure 4. Dynamic Threshold and Finite State Machine (FSM) proposed in [26].

$$\text{Upper_Threshold} = \text{Amplitude} * (1 + \text{noise}). \tag{7}$$

$$\text{Lower_Threshold} = \text{Amplitude} * (1 - \text{noise}). \tag{8}$$

The five states for FSM defined in [27] are shown in Figure 4. Any change in signal amplitude that can be detected by lower and upper threshold, corresponds to transitions of states and maintains aiming arrival and departure time of pulse, and is saved into stacks. Then PW is calculated using saved data of TOA and TOD, as presented in the following equations,

$$\text{PW} = \text{TOD} - \text{TOA}. \tag{9}$$

$$\text{PRI} = \text{Pulse 2 (TOA)} - \text{Pulse 1 (TOA)}. \tag{10}$$

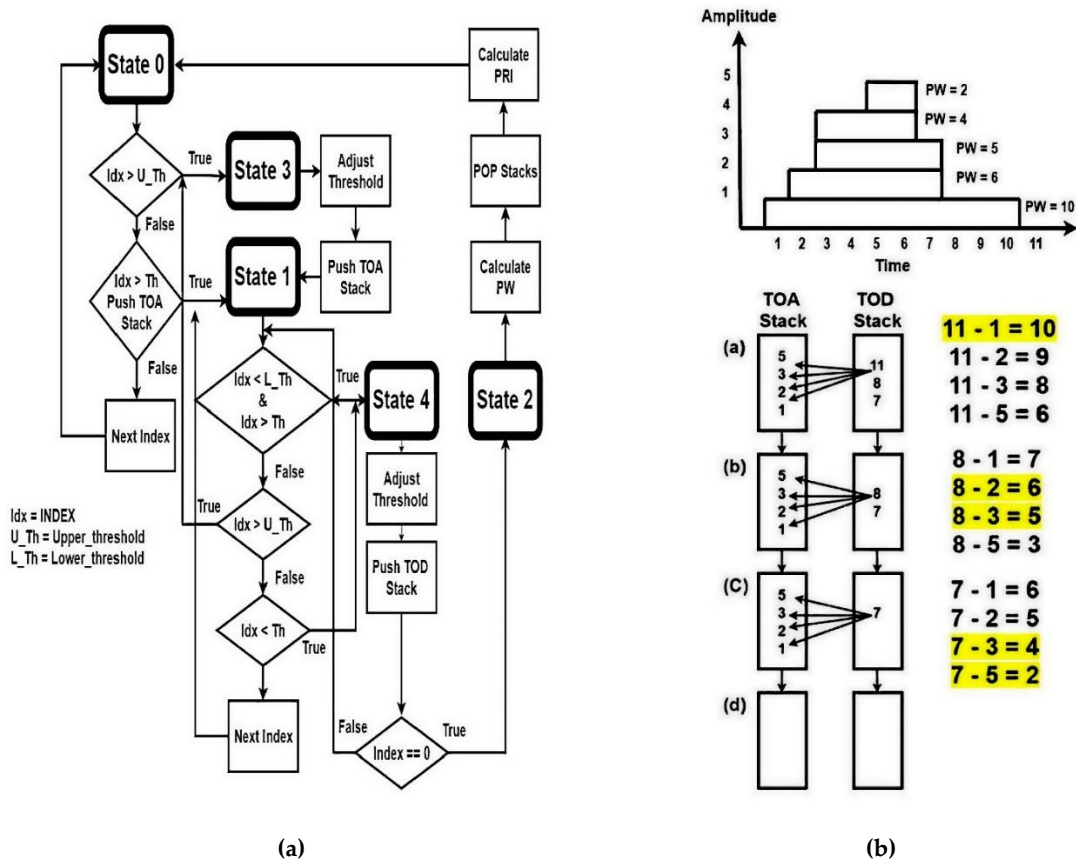

Figure 5. Pulse On Pulse (POP) Deinterleaving Algorithm: (a) Deinterleaving algorithm flowchart; (b) Finding PWs of a POP using TOA and TOD stack.

Table 2. Confirmation Rate with 8 Signals of POP method proposed in [27]

Radar Emitter	TOA(%)	PW(%)	PRI (%)
A1	100%	100%	100%
A2	100%	100%	0%
A3	100%	100%	100%
A4	100%	100%	40%
A5	100%	100%	0%
A6	100%	100%	0%
A7	100%	100%	0%
A8	100%	100%	0%
False Emitter 1	100%	100%	0%

Figure (5) shows the Pulse On Pulse (POP) deinterleaving algorithm. Simulation results in reference [27] demonstrate high reliability for estimating interleaved parameters, as shown in Table 2.

3. Comparison of Interference Suppression Techniques

Table 4 shows a detailed comparison of the interference suppression techniques discussed. It is clear from the table that the (STAP) technique is the preferable one but combining the (MVDR) technique with it improves the interference signal detection.

Table 4. Comparison of the interference suppression techniques

Point of view	SCORE, PI, MUSIC Algorithms [1-3],[7-8]	Multi Objective Optimization [4]	STAP [5],[6]][9]	LMS, RLS Algorithms [29]
suppression technique type	adaptive nulling algorithm	adaptive nulling algorithm	Digital beam forming	Digital beam forming
GPS signal location prior knowledge	No need	No need	No need	Needed
Null toward jammers directions	Wide null	Narrow nulls	---	---
No. of interference directions	Depend on antenna elements (M-1)	Depend on antenna elements (M-1)	Increase antenna array degree of freedom without adding elements	Performance degraded severely if errors of estimating signals increased
Complexity	Simplex	simplex	simplex	Quite complex

4. Proposed Interference Suppression Filters

Spoofing requires matching the operating cycle of the GNSS desired signal. For effective results, spoofing pulses should cover the desired pulses as an initial step to unlock tracking of the desired signal and force GPS receiver to track in spurious signal [30]. The first proposed technique is to design a post correlation two-stage filter in the GPS receiver to optimize the acquisition of GPS signal in the presence of interference, and to detect the presence of spoofing; the first stage filter is to detect the presence of spoofing, or we can say in other words detection of carrier in carrier by calculating the fourth joint cumulant of the received signal and its conjugate, by comparing the cumulant with threshold. If the value of the cumulant exceeds the limits the decision is the absence of spoofing, and if the value does not exceed the threshold the decision is presence of spoofing [31]. The second stage filter is to get the optimal acquisition of GPS signal in the presence of powerful interference by calculating the cross-ambiguity function (CAF) by searching the maximum range instead of maximum cell value for each doppler frequency in CAF, and then calculating the sum of distances for each doppler frequency [32]. Figure 6 demonstrates a block diagram of the proposed filter designed to detect spoofing and optimize the acquisition of GPS signal in the presence of interference. The effectiveness of the proposed filter is now under investigation. Another recommended design is based on pulse-on-pulse method mentioned in Section 2.6. As the C/A code has 20 repetitive cycles within data chip rate [33], so based on this privilege, a recommended filter design is demonstrated in Figure 7 that can deinterleave desired signals in the presence of noise or spoofing. The effectiveness of the proposed filter is also under investigation.

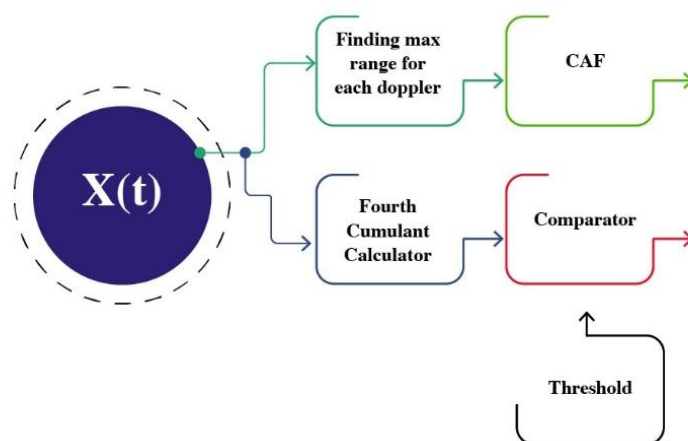

Figure 6. Block diagram of proposed filter.

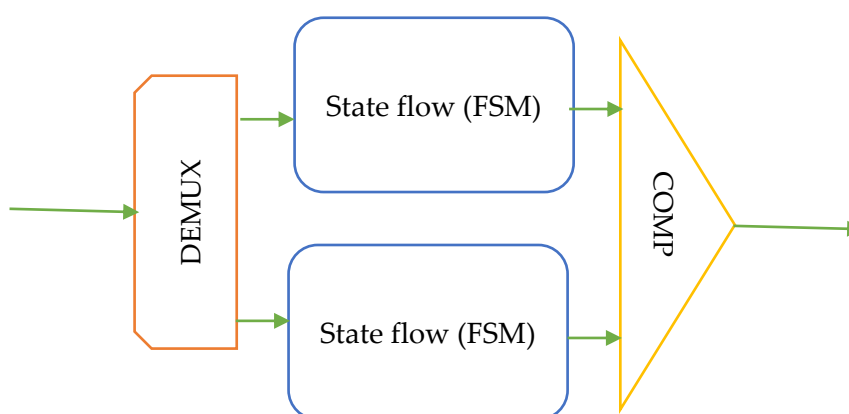

Figure 7. Block diagram of FSM proposed filter

5. Conclusions

A thorough survey of different suppression techniques in GNSS receiver is presented. A review of the different interference suppression techniques, such as SCORE algorithm, the multi-objective optimization jamming mitigation algorithm, STAP technology, FOS technique and dual polarized antenna technique is presented. Two filter designs to improve interference suppression are proposed; First: an interference suppression post correlation two-stage filter, that can detect the presence of spoofing and suppress the strong interference signals. The filter does not require prior information on the interference signal characteristics, and therefore, its performance does not depend on the accuracy of the interference signal characteristics estimation. Second: A design that can deinterleave desired signals in the presence of noise or spoofing and is based on pulse-on-pulse method. The effectiveness of the proposed filters is under investigation.

References

1. Brown, A.; Gerein, N. Test results of a digital beamforming GPS receiver in a jamming environment. *Proceedings of ION GPS, Salt Lake City, Utah, USA September 2001*.
2. Lu, D.; Feng, Q.; Wu, R. Survey on interference mitigation via adaptive array. *Progress in electromagnetics research symposium 2006, Cambridge, USA, March 26-29*, pp. 357-362. 2006,
3. Agee, B.; Schell, S.; Gardner, W. Spectral self-coherence restoral: A new approach to blind adaptive signal extraction using antenna array, *Proceedings of the IEEE, Volume. 78*, no. 4, pp. 753-767, April 1990.
4. Lang, R; Xiao H, Li Z, Yu L. A antijamming method for satellite navigation system based on multi-objective optimization technique. *PLoS ONE 12(7)*: e0180893, 2017. <https://doi.org/10.1371/journal.pone.0180893>.
5. Wenlin, Liu; Chang Qing. Implementation of STAP algorithm based on FPGA of anti-jamming GPS receiver, *Space Electronic Technology*, 2008.

6. Xiaochang, S; Huangfu,K; Chen Qing. Joint space-time adaptive filtering for GPS anti-jamming receiver, *Journal of China Institute of Communications*, vol. 25, No. 8, August 2004.
7. Ahmad, Z. S.; Song, Y. L.; Du, Q. Convergence analysis of null steering antenna utilizing power inversion algorithm. *IEEE International Seminar/Workshop on Direct and Inverse Problems of Electromagnetic and Acoustic Wave Theory*, 2015, Sept., pp. 21-24; Lviv, Ukraine; 10.1109/DIPED.2015.7324263.
8. Schmidt, R. O. Multiple Emitter Location and Signal Parameter Estimation. *IEEE Transactions on Antennas and Propagation*. 1986; 34(3): pp. 276-280.
9. Zhao; Hongwei; Lian, B; Juan Feng. Space-Time Adaptive Processing for GPS Anti-Jamming Receiver. *Physics Procedia*, Volume 33, 2012, pp. 1060-1067, ISSN 1875-3892.
10. Elghamrawy, H.; Karaim, M.; Korenberg, M.; Noureldin, A. High-Resolution Spectral Estimation for Continuous Wave Jamming Mitigation of GNSS Signals in Autonomous Vehicles. in *IEEE Transactions on Intelligent Transportation Systems*, doi: 10.1109/TITS.2021.3074102.
11. Korenberg, M. J.; A robust orthogonal algorithm for system identification and time-series analysis. *Biol. Cybern.*, vol. 60, no. 4, pp. 267–276, Feb. 1989.
12. Chon, K. H. Korenberg, M. J.; Holstein-Rathlou, N. H. Application of fast orthogonal search to linear and nonlinear stochastic systems. *Ann. Biomed. Eng.*, vol. 25, no. 5, pp. 793–801, Sep. 1997.
13. Tamazin, M.; Noureldin, A.; Korenberg M. J. Robust modeling of low-cost MEMS sensor errors in mobile devices using fast orthogonal search. *J. Sensors*, vol. 2013, pp. 1–8, 2013.
14. Chon, K. H. Accurate identification of periodic oscillations buried in white or colored noise using fast orthogonal search. *IEEE Trans. Biomed. Eng.*, vol. 48, no. 6, pp. 622–629, Jun. 2001.
15. Massoud, A. Direction of arrival estimation in passive sonar systems. *Ph.D. dissertation, Dept. Elect. Comput. Eng., Queen's Univ., Kingston, ON, Canada*, May 2012.
16. Osman, A., Nourledin, A.; El-Sheimy, N.; Theriault, J.; Campbell, S. Improved target detection and bearing estimation utilizing fast orthogonal search for real-time spectral analysis, *Meas. Sci. Technol.*, vol. 20, no. 6, Apr. 2009, Art. no. 065201.
17. Moussa, M. High resolution jamming detection in global navigation satellite systems. *Ph.D. dissertation, Dept. Electr. Comput. Eng., Queen's Univ., Kingston, ON, Canada*, May 2015.
18. Abosekeen, A.; Noureldin, A.; Korenberg, M. J. Improving the RISS/GNSS land-vehicles integrated navigation system using magnetic azimuth updates. *IEEE Trans. Intell. Transp. Syst.*, vol. 21, no. 3, pp. 1250–1263, Mar. 2020.
19. Abosekeen, A.; Iqbal, U.; Noureldin, A. ; Korenberg, M. J. A novel multi-level integrated navigation system for challenging GNSS environments. *IEEE Trans. Intell. Transp. Syst., early access*, Mar. 18, 2020, doi: 10.1109/TITS.2020.2980307.
20. Park, K.; Lee, D.; Seo, J. Dual-polarized GPS antenna array algorithm to adaptively mitigate a large number of interference signals. *Aerospace Science and Technology*, Volume 78, 2018, pp. 387-396, ISSN 1270-9638,
21. Fante, R. L.; Vaccaro, J. J. Evaluation of adaptive space-time-polarization cancel-lation of broadband interference. in: *Proc. 2002 IEEE Position Location and Navigation Symposium, Palm Springs, CA, USA*, 2002, pp.1–3.
22. Amin, M.G. Sequential interference nulling and localization in two-dimensional GPS receiver array. in: *Proc. 20th International Technical Meeting of the Satellite Division of The Institute of Navigation, Fort Worth, TX, USA*, 2007, pp.1257–1264.
23. Wang, J.; Amin, M.G. Multiple interference cancellation performance for GPS receivers with dual-polarized antenna arrays. *EURASIP J. Adv. Signal Process.* 2008(1) (2008) 597613.
24. Compton, R.T. On the performance of a polarization sensitive adaptive array. *IEEE Trans. Antennas Propag.* 29(5) (1981) 718–725.
25. Park, K.; Seo, J. Single-Antenna-Based GPS Antijamming Method Exploiting Polarization Diversity. in *IEEE Transactions on Aerospace and Electronic Systems*, vol. 57, no. 2, pp. 919-934, April 2021, doi: 10.1109/TAES.2020.3034025.
26. Sun, K.; Zhang, T. A New GNSS Interference Detection Method Based on Rearranged Wavelet–Hough Transform. *Sensors* 2021, 21, 1714. <https://doi.org/10.3390/s21051714>
27. Erdogan, J.; Lin, J. J.; George, K. Pulse on Pulse Deinterleaving Radar Algorithm. 2020 10th Annual Computing and Communication Workshop and Conference (CCWC), 2020, pp. 0373-0377, doi: 10.1109/CCWC47524.2020.9031148
28. Xi, Y.; Wu, Y.; Wu, X.; Jiang, K. An improved SDIF algorithm for anti-radiation radar using dynamic sequence search. 2017 36th Chinese Control Conference (CCC), Dalian, 2017, pp. 5596-5601.
29. Ali, R. L.; Ali, A.; ur-Rehman, A.; Shahid A. K.; Shahzad, A. M. Adaptive Beamforming Algorithms for Anti-Jamming. *International Journal of Signal Processing, Image Processing and Pattern Recognition* Vol. 4, No. 1, pp. 95-105, March 2011.
30. Vakin, S. A.; Shustov, L. N.; Dunwell, R. H. Fundamentals of Electronic Warfare (*Artech House Radar Library*) (*Artech House Radar Library (Hardcover)*) (1st ed.). Artech Print on Demand. (2001).
31. Semenov, V.; Omelchenko, P.; Kruhlyk, O. Method for the Detection of Carrier in-Carrier Signals Based on Fourth-Order Cumulants. pp. 25–32, 2019.
32. Aghadadashfam, M.; Mosavi, M. R.; Rezaei, M. J. A new post-correlation anti-jamming technique for GPS receivers. *GPS Solutions* (2020) 24:89. <https://doi.org/10.1007/s10291-020-01004-y>.
33. Wu,R.; Wang,W.; Lu, D.; Wang, L.; Jia, Q. Springer Malaysia Representative.2018, *Singapore Springer* ISBN: 9789811055706.